



AltRider DualControl Brake System for YAMAHA SUPER TENERE INSTALLATION INSTRUCTIONS

The most up to date instructions can be downloaded from the product page at altrider.com, under the instructions tab.

Dear Rider,
Thank you for choosing AltRider! Whether a seasoned world adventurer or a first time ADV-Newbie, we welcome you to the AltRider experience. You can install your new product with the utmost confidence. AltRider designs, tests, and manufactures all of its products here in the United States. We are proud to do what we do, and honored to present to you the product of our labors.

Enjoy it, show it off, and most of all, **RIDE IT!**

Venture On,
Jeremy LeBreton



Yamaha Super Tenere DualControl Brake System

Package Contents:
- Enlarger kit
- Instructions

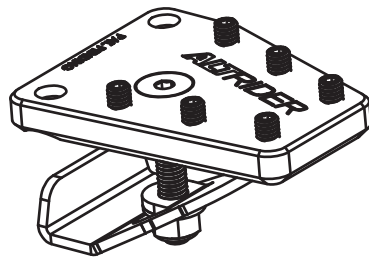

AltRider LLC

Global

mailing: 4000 Aurora Ave N Ste 100
Seattle, WA 98103 USA
phone: 206-922-3618
email: info@altrider.com
web: www.altrider.com

Europe

mailing: Heliumstraat 230
2718 RS Zoetermeer
The Netherlands
email: info@altrider.eu
web: www.altrider.eu

REV 5.2

Rev 0.2

MADE IN THE USA



Enlarger Kit:

- ① Brake Pedal Enlarger
- ② (6) M4 x 8mm long grip pins
- ③ M5 x 20 flat head screw
- ④ Steel bottom plate
- ⑤ M5 washer
- ⑥ M5 lock nut

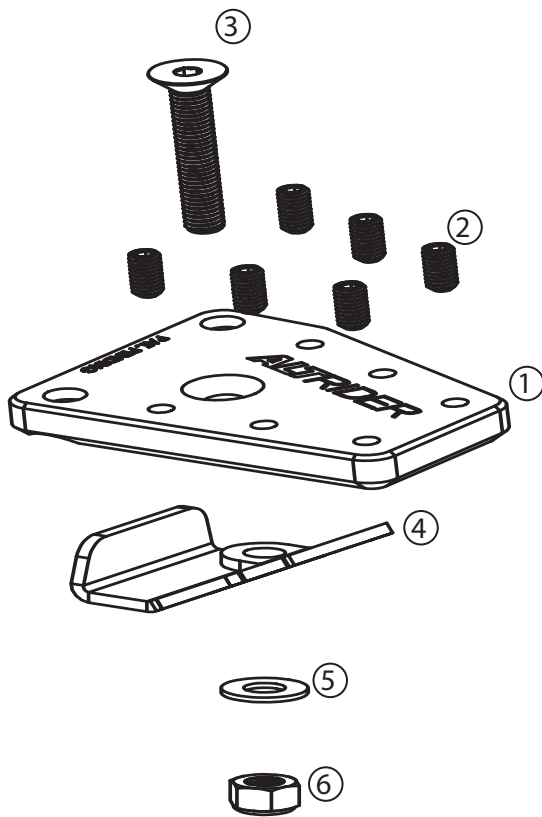

Riser Kit (Optional):

- ① Riser block
- ② (5) M4 x 8mm long grip pins
- ③ (2) M5 x 12 flat head screws

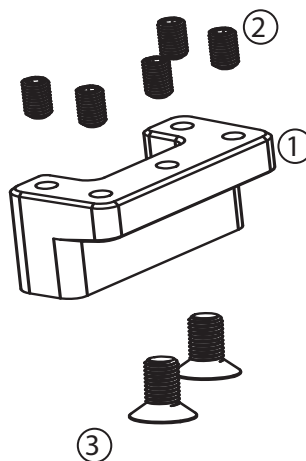

Installation Tools

- ① 2mm Allen key
- ② 3mm Allen key
- ③ 8mm socket
- ④ Thread locker



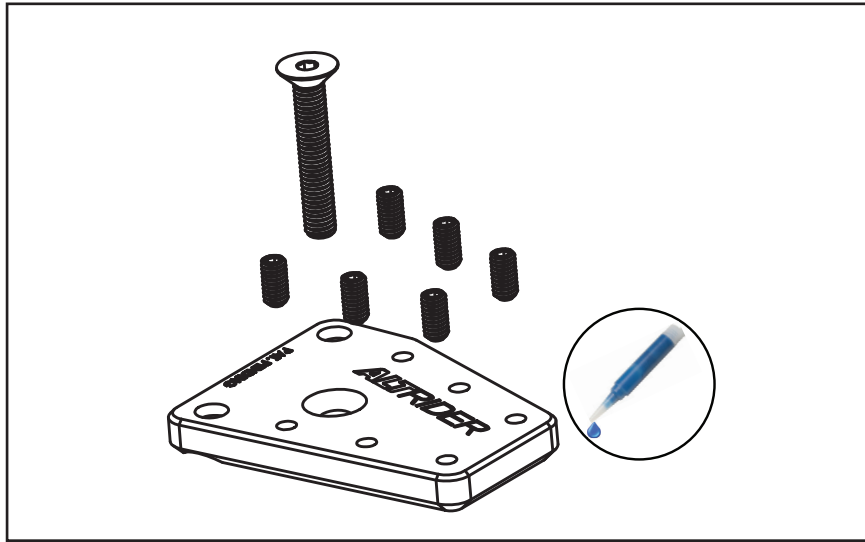

- ① Install M4 x 8mm Grip pins, using 2mm Allen driver. Use a small dot of thread locker on each pin. Total number and placement is up to you. Tighten snug, but be careful not to strip the tool. Insert the M5 x 20mm flathead screw through the enlarger.

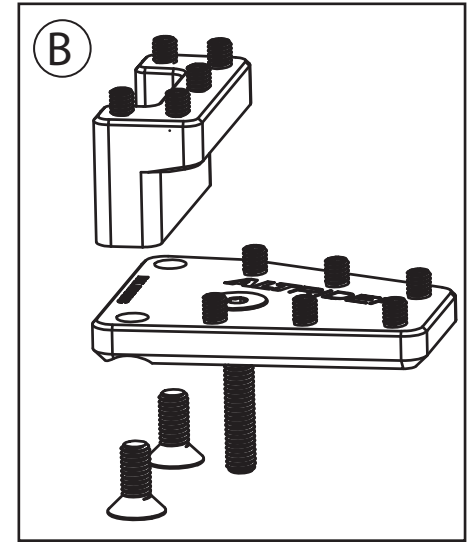
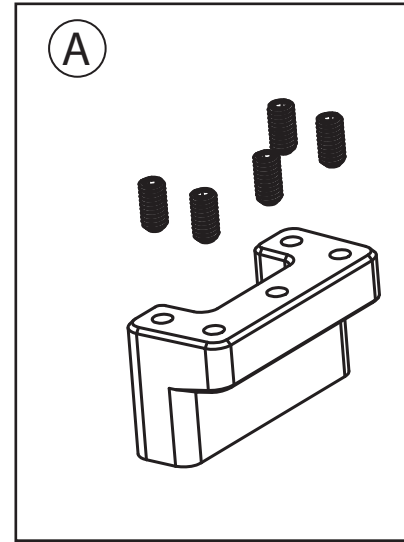

- ② If your kit is equipped with the optional Riser, install the grip pins in the riser now. (A) Then apply drop of thread locker to the two M5 x 12mm flat head screws, and attach the riser to the enlarger base (B).

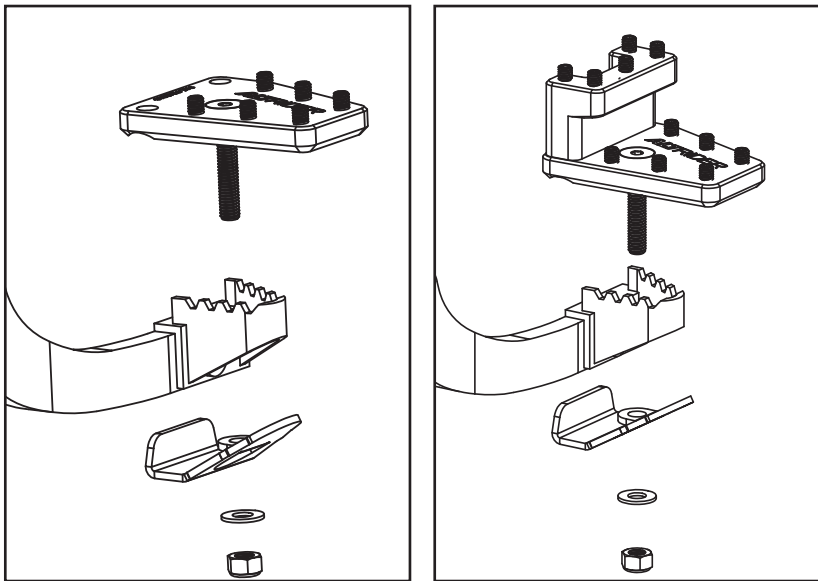

- ③ Place enlarger on brake pedal tip. Use 8mm socket tool to attach steel lower plate with M5 washer and M5 locknut. Tighten to 4.4Nm.

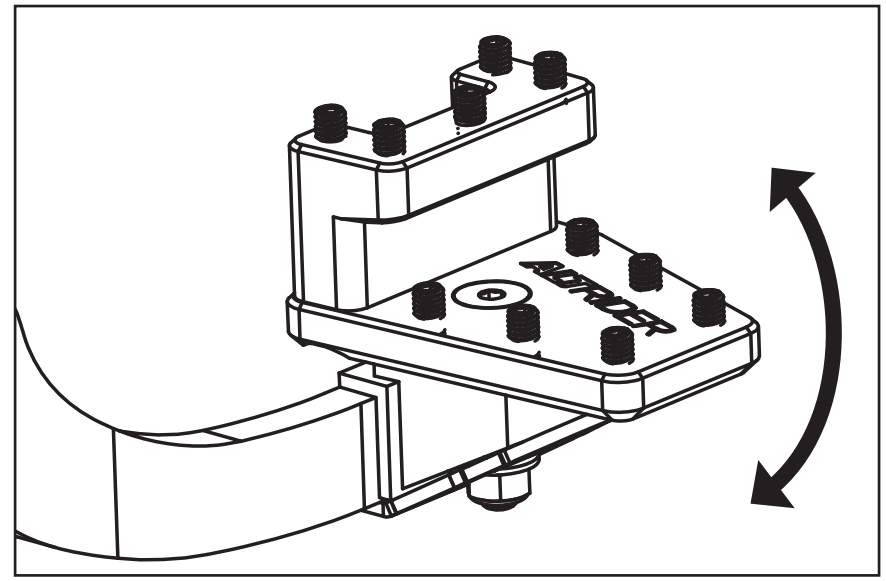

- ④ Check brake pedal movement to be sure there is no interference with other parts of your bike.

Brake Lever Adjustment to lower height. (optional)

There is a moderate amount of adjustment available from the OEM lever. If you find the dual control now requires the entire lever to move down for better ergonomics, here are the steps to accomplish that fine adjustment.

Begin with your lever adjusted to the correct factory position. It is important that you start with your lever correctly adjusted. Mis-adjustment can cause the caliper to bind prematurely. A certain amount of free play is required because as the brake system heats up the free play is taken up by the expanding materials. Incorrect adjustment can result in significant damage to the brake pads and rotors, and could possibly cause the rear brakes to be permanently squeezed "on", even with no pressure on the lever itself.

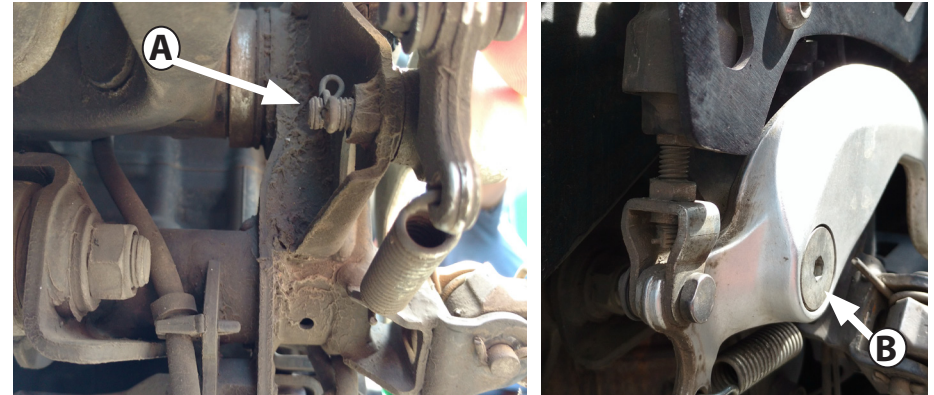
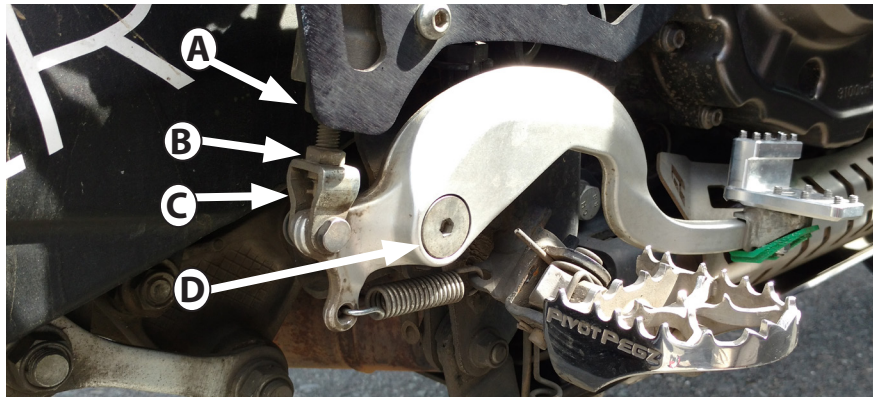

- ① Locate the master cylinder and plunger connected to the brake pedal, directly behind the right side foot peg. Note parts: (A) plunger shaft wrench flats. (B) Jam nut. (C) Yoke. (D) Pivot (with hairpin cotter on back end.)
- ② Remove the hairpin cotter pin (A) from the back end of the brake lever pivot (B)

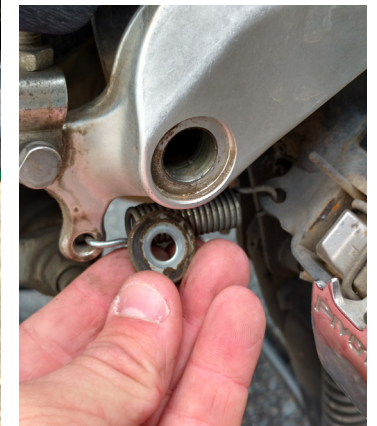

- ③ Use pliers to remove hairpin cotter from step 2.
- ④ Use 6mm allen to remove brake lever pivot. Be aware of thrust washer that is behind the lever will drop out. Save for reinstallation.

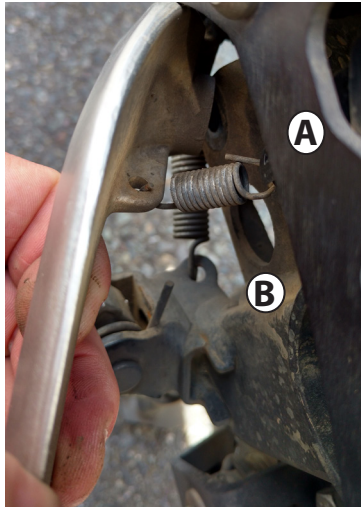

⑤ Detach two springs (A and B) that are attached to the brake lever.



⑥ Use 10mm spanner to hold the master cylinder shaft still. (A)
Use 12mm spanner to loosen the jam nut that is against the yoke. (B)



⑦ Hold plunger still (do not rotate). Turn entire brake lever to move the yoke up or down on the shaft. This will set your new lever height. Spinning the yoke up the shaft will move your brake lever tip downwards.



⑧ There is a limit to how much adjustment is available, make sure the plunger tip does not contact the brake lever at the very lowest height setting. Once adjusted to your preference, use the 10mm spanner to hold the shaft still, and use the 12mm spanner to tighten the nut against the yoke.



- ⑤ Hole the thrust washer in place behind the brake lever, and reinsert the brake lever pivot. Screw tight with 6mm allen tool. Reinstall hairpin cotter, be sure small bend tip is secure over end of bolt.

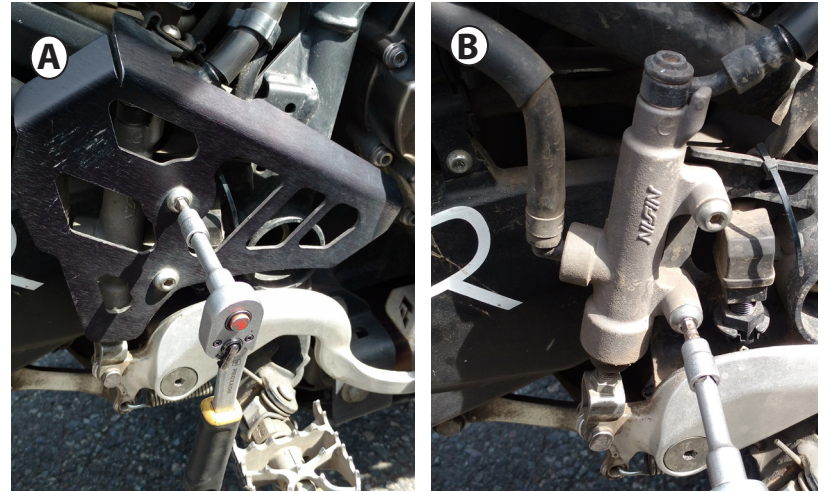

- ⑥ The change in lever height requires adjustment of the rear brake light switch. Remove rear brake master cylinder cover.(A) Reinstall bolts to hold the master cylinder in place. (B)



- ⑦ With 17mm spanner, turn the plastic nut that adjusts the brake light switch height. Hold the switch stationary and gently turn the nut. If you moved your lever tip downward, you will need to turn the nut counter-clockwise to lower the switch to match.



- ⑧ Turn on your key and test the function of your brake lever switch. Once set satisfactorily, reinstall master cylinder cover. Tighten all bolts.

CONGRATULATIONS!

You've completed your installation. If at any point you have questions about your installation or have any feed back for us, we'd love to hear it. A downloadable version of these instructions can be found at our web site. www.AltRider.com

After 5 hours or 100 miles of riding, check your newly installed equipment to ensure all hardware is secure.

Global Office:

email: info@AltRider.com
phone: +1 206-922-3618
address: 4000 Aurora Ave N
Ste 100
Seattle, WA 98103

Europe

mailing: Heliumstraat 230
2718 RS Zoetermeer
Netherlands
email: info@altrider.eu
web: www.altrider.eu

TERMS OF USE, WARRANTY AND LIABILITY WAIVER

AltRider LLC, a Washington company, having its principal place of business in Seattle, WA ("AltRider") offers its motorcycle accessories (the "Product") with the terms, conditions and notices as follows:

Terms of Use

This Product is offered to you conditioned upon your acceptance without modification of the terms, conditions, and notices contained herein. Installation and/or use of this product implies acceptance of all such terms, conditions, and notices. If you do not agree to these terms, do not buy the Product. If you have already bought the Product and do not agree to these terms, return this Product promptly including the packaging and all written materials, to AltRider.

Limitation of Liability and Warranty Disclaimer

You may return your merchandise for a full refund or exchange, less any original or return shipping fees under these conditions:

1. Only if the merchandise is in 100% factory condition. Original manufacturer's packaging and same condition as sold – original boxes, packaging material, instructions, documentation, parts, and attached tags.
2. Only unused, unscratched, uninstalled, undamaged merchandise will be accepted. Do not install equipment until you are sure you want to keep it. Package items carefully in protective materials before returning them. Never ship an item in its original manufacturers packaging – it will arrive damaged. Please use a postal box or other adequate packaging to ensure your return or exchange is not damaged on the way back to AltRider.com.

To read more about our exchanges and returns policy, on the web, navigate to <http://www.altrider.com/info/exchangesAndReturns>

Excepting the warranties stated in the preceding paragraph, AltRider hereby disclaims all other warranties and conditions with regard to the Product including all implied warranties and conditions of merchantability and fitness for a particular purpose. There are no warranties which extend beyond the description on the face hereof. AltRider does not warrant against damages or defects arising out of use or installation of the Product. Installation instructions are provided for your convenience. AltRider is not responsible for any damages arising out of the installation, improper or otherwise, of the Product. No warranty of any kind, expressed or implied, is made regarding the safety of this Product.

To the extent allowed by law, AltRider shall not be held liable for any direct, indirect, punitive, incidental, special or consequential damages arising out of, or connected with, the use or misuse of this Product. Buyer assumes all risks and liability arising from use of this Product.

Entire Agreement

This document states the entire obligation of AltRider with respect to the Product. If any part of this agreement is determined to be void, invalid, unenforceable or illegal, including, but not limited to the warranty disclaimers and liability limitations set forth above, then the remainder of the agreement shall remain in full force and effect.

Applicable Law

This agreement is governed by the laws of Washington, USA. You hereby consent to the exclusive jurisdiction and venue of the courts of Washington, USA, in all disputes arising out of or relating to the use of this product.

